



TEST REPORT

According to ANSI/IES LM-80-15

For

Hongli Zhihui Group Co.,Ltd. Guangzhou Branch

Room 316, Building 2, No.1, Xianke Yi Road, Huadong Town, Huadu District, Guangzhou, China

Model: HL-C3535K9W1EA(Ra1)-FC

| | | | |
|--|--|-------------------------------------|--|
| Report Type: 10000 Hours Test Report | | Product Type: LED Package | |
| Reviewed By: | Pote Wang | <i>Pote Wang</i> | |
| Report Number: | RSZ201026503-10-10000-M2 | | |
| Test Date: | 2020-11-23 to 2022-01-20 | | |
| Report Date: | 2024-04-25 | | |
| Approved by: | Blake Zhang / EE Engineer | <i>Blake Zhang</i> | |
| Revised Note: | The previous report RSZ201026503-10-10000-M1 is replaced by this report on 2024-04-25 | | |
| Prepared By: | Bay Area Compliance Laboratories Corp. (Dongguan). No.12, Pulong East 1 st Road, Tangxia Town, Dongguan, Guangdong, China. Tel: +86-0769-86858888 Fax:+86-0769-86858588 | | |

TABLE OF CONTENTS

| | |
|--|-----------|
| 1 - General Information | 3 |
| 1.1 Description of LED Light Sources | 3 |
| 1.2 Standards and Reference Documentations | 5 |
| 1.3 Testing Equipment | 5 |
| 1.4 Drive Level | 5 |
| 1.5 Ambient Conditions for Maintenance Test | 5 |
| 1.6 Photometric Measurement Method and Uncertainty | 6 |
| 1.7 Statement of Traceability | 6 |
| 1.8 Sample Set | 6 |
| 2 - Summary of Test Result | 7 |
| 3 - Test Data | 8 |
| 3.1 Data Set 1, 55°C, 800mA (Lumen Maintenance) | 8 |
| 3.2 Data Set 1, 55°C, 800mA (Forward Voltage) | 9 |
| 3.3 Data Set 1, 55°C, 800mA (Chromaticity Shift) | 10 |
| 3.4 Data Set 2, 105°C, 800mA (Lumen Maintenance) | 11 |
| 3.5 Data Set 2, 105°C, 800mA (Forward Voltage) | 12 |
| 3.6 Data Set 2, 105°C, 800mA (Chromaticity Shift) | 13 |
| 4 - DUT Photo | 14 |
| 4.1 Mechanical Dimensions | 14 |
| 4.2 DUT Photo | 14 |
| 5 - Report Revision | 15 |
| Directions | 16 |

1 - General Information

1.1 Description of LED Light Sources

Sample Size:

60 PCS test samples were in good condition and received on 2020-10-26. The samples were numbered from 1 to 30 and 31 to 60.

| | |
|---------------------------------------|---|
| Manufacturer: | Hongli Zhihui Group Co.,Ltd. Guangzhou Branch |
| Part Number: | HL-C3535K9W1EA(Ra1)-FC |
| Part Type: | LED Package |
| #Drive Level: | DC 800mA |
| #Nominal CCT: | 2700K |
| #Power: | 2.34 W |
| #Average Current Density per LED die: | 410mA/mm ² |
| #Average Power Density per LED die: | 1.2W/mm ² |
| #CRI: | 70 |
| #Die Spacing: | NA |

Sampling Method:

LED samples for IESNA LM-80 testing consist of units built from a minimum of three manufacturing lots with each manufacturing lot built from different wafer lots built on non-consecutive days.

These manufacturing lots are picked to represent a wide parametric distribution.

Family products covered by this report:

According to *ENERGY STAR[®] Requirements for the Use of LM-80 Data*, the following products can be covered by this report base on the information and declaration provided by manufacturer. The information of these models shows that the covered products meet all section 4 requirements of *ENERGY STAR[®] Requirements for the Use of LM-80 Data* (September 28, 2017)

This report covers the following models:

| Series Name | Model Name | Total Input Current (mA) | Power (W) | CCT (K) | Number of dies | Driver current per die (mA) | Current Density per Die (mA/mm ²) | Power Density per PCB (W/mm ²) | Die Spacing (mm) |
|----------------|------------------------------|--------------------------|-----------|-----------|----------------|-----------------------------|---|--|------------------|
| Test model | HL-C3535K9W1EA(Ra1)-FC | 800 | 2.34 | 2700 | 1 | 800 | 410 | 0.1932 | / |
| Multiple model | HL-C3535K9W1EA(Ra1)-FC | 800 | 2.34 | 2700-6500 | 1 | 800 | 410 | 0.1932 | / |
| Multiple model | HL-C3535K9W1EA(Ra1)-FC-LVR | 800 | 2.34 | 2700-6500 | 1 | 800 | 410 | 0.1932 | / |
| Multiple model | HL-C3535F77W1EA(Ra1)-FC | 500 | 1.4 | 2700-6500 | 1 | 500 | 383 | 0.1176 | / |
| Multiple model | HL-C3535F77W1EA(Ra1)-FC-LVR | 500 | 1.4 | 2700-6500 | 1 | 500 | 383 | 0.1176 | / |
| Multiple model | HL-C3535K9W1GA(Ra1)-FC | 800 | 2.34 | 2700-6500 | 1 | 800 | 410 | 0.1932 | / |
| Multiple model | HL-C3535K9W1GA(Ra1)-FC-LVR | 800 | 2.34 | 2700-6500 | 1 | 800 | 410 | 0.1932 | / |
| Multiple model | HL-C3535F77W1GA(Ra1)-FC | 500 | 1.4 | 2700-6500 | 1 | 500 | 383 | 0.1176 | / |
| Multiple model | HL-C3535F77W1GA(Ra1)-FC-LVR | 500 | 1.4 | 2700-6500 | 1 | 500 | 383 | 0.1176 | / |
| Multiple model | HL-C3535K9W1EA(Ra1)-FC(Ag60) | 800 | 2.34 | 2700-6500 | 1 | 800 | 410 | 0.1932 | / |

| | | | | | | | | | |
|----------------|---------------------------------------|-----|------|-----------|---|-----|-----|--------|---|
| Multiple model | HL-C3535F77W1EA(Ra1) -FC(Ag60) | 500 | 1.4 | 2700-6500 | 1 | 500 | 383 | 0.1176 | / |
| Multiple model | HL-C3535K9W1EA(Ra1) -FC(Au120)-CY | 800 | 2.34 | 2700-6500 | 1 | 800 | 410 | 0.1932 | / |
| Multiple model | HL-C3535F77W1EA(Ra1) -FC(Au120)-CY | 500 | 1.4 | 2700-6500 | 1 | 500 | 383 | 0.1176 | / |
| Multiple model | HL-C3535K9W1GA(Ra1) -FC(Au120)-CY | 800 | 2.34 | 2700-6500 | 1 | 800 | 410 | 0.1932 | / |
| Multiple model | HL-C3535F77W1GA(Ra1) -FC(Au120)-CY | 500 | 1.4 | 2700-6500 | 1 | 500 | 383 | 0.1176 | / |
| Multiple model | HL-C3535K9W3GA(Ra1) -FC | 800 | 2.34 | 2700-6500 | 1 | 800 | 410 | 0.1932 | / |
| Multiple model | HL-C3535F77W3GA(Ra1) -FC | 500 | 1.4 | 2700-6500 | 1 | 500 | 383 | 0.1176 | / |
| Multiple model | HL-C3535K9W5GA(Ra1) -FC | 800 | 2.34 | 2700-6500 | 1 | 800 | 410 | 0.1932 | / |
| Multiple model | HL-C3535F77W5GA(Ra1) -FC | 500 | 1.4 | 2700-6500 | 1 | 500 | 383 | 0.1176 | / |
| Multiple model | HL-C3535K9W3GA(Ra1) -FC-LVR | 800 | 2.34 | 2700-6500 | 1 | 800 | 410 | 0.1932 | / |
| Multiple model | HL-C3535F77W3GA(Ra1) -FC-LVR | 500 | 1.4 | 2700-6500 | 1 | 500 | 383 | 0.1176 | / |
| Multiple model | HL-C3535K9W5GA(Ra1) -FC-LVR | 800 | 2.34 | 2700-6500 | 1 | 800 | 410 | 0.1932 | / |
| Multiple model | HL-C3535F77W5GA(Ra1) -FC-LVR | 500 | 1.4 | 2700-6500 | 1 | 500 | 383 | 0.1176 | / |
| Multiple model | HL-C3535K9W1GA(Ra1) -FC-LVR-QX | 800 | 2.34 | 2700-6500 | 1 | 800 | 410 | 0.1932 | / |
| Multiple model | HL-C3535F77W5GA(Ra1) -FC-LVR-QX | 500 | 1.4 | 2700-6500 | 1 | 500 | 383 | 0.1176 | / |
| Multiple model | HL-C3535K29W5KB(Ra1)-FC-LVR | 800 | 2.34 | 2700-6500 | 1 | 800 | 230 | 0.1932 | / |
| Multiple model | HL-C3535K29W5KB(Ra1)-FC | 800 | 2.34 | 2700-6500 | 1 | 800 | 230 | 0.1932 | / |
| Multiple model | HL-C3535K29W3KA(Ra1)-FC-LVR | 800 | 2.34 | 2700-6500 | 1 | 800 | 230 | 0.1932 | / |
| Multiple model | HL-C3535K29W3KA(Ra1)-FC | 800 | 2.34 | 2700-6500 | 1 | 800 | 230 | 0.1932 | / |
| Multiple model | HL-C3535F77W3KA(Ra1)-FC-LVR | 480 | 1.40 | 2700-6500 | 1 | 480 | 410 | 0.114 | / |
| Multiple model | HL-C3535F77W3KA(Ra1)-FC | 480 | 1.40 | 2700-6500 | 1 | 480 | 410 | 0.114 | / |
| Multiple model | HL-C3535F77W1EB(Ra1)-FC-LVR(Ag60) | 480 | 1.40 | 2700-6500 | 1 | 480 | 410 | 0.114 | / |
| Multiple model | HL-C3535F77W3PA(Ra1)-FC-LVR | 480 | 1.40 | 2700-6500 | 1 | 480 | 410 | 0.114 | / |
| Multiple mode | HL-C3535F77W3PA(Ra1)-FC | 480 | 1.40 | 2700-6500 | 1 | 480 | 410 | 0.114 | / |
| Multiple model | HL-C3535K9W5KA(Ra1)-FC-LVR | 800 | 2.34 | 2700-6500 | 1 | 800 | 410 | 0.1932 | / |
| Multiple model | HL-C3535K9W5KA(Ra1)-FC | 800 | 2.34 | 2700-6500 | 1 | 800 | 410 | 0.1932 | / |
| Multiple model | HL-C3535K9W5KB(Ra1)-FC-LVR | 800 | 2.34 | 2700-6500 | 1 | 800 | 410 | 0.1932 | / |

| | | | | | | | | | |
|----------------|----------------------------------|-----|------|-----------|---|-----|-----|--------|---|
| Multiple model | HL-C3535K9W5KB(Ra1)-FC | 800 | 2.34 | 2700-6500 | 1 | 800 | 410 | 0.1932 | / |
| Multiple model | HL-C3535K9W5EB(Ra1)-FC-LVR(Ag60) | 800 | 2.34 | 2700-6500 | 1 | 800 | 410 | 0.1932 | / |
| Multiple model | HL-C3535K9W5PA(Ra1)-FC-LVR | 800 | 2.34 | 2700-6500 | 1 | 800 | 410 | 0.1932 | / |
| Multiple model | HL-C3535K9W5PA(Ra1)-FC | 800 | 2.34 | 2700-6500 | 1 | 800 | 410 | 0.1932 | / |
| Multiple model | HL-C3535K9W5PB(Ra1)-FC-LVR | 800 | 2.34 | 2700-6500 | 1 | 800 | 410 | 0.1932 | / |
| Multiple model | HL-C3535K9W5PB(Ra1)-FC | 800 | 2.34 | 2700-6500 | 1 | 800 | 410 | 0.1932 | / |
| Multiple model | HL-C3535K9W3PA(Ra1) -FC-LVR2-F | 800 | 2.34 | 2700-6500 | 1 | 800 | 410 | 0.1932 | / |
| Multiple model | HL-C3535K9W1KA(Ra1)-FC | 800 | 2.34 | 2700-6500 | 1 | 800 | 410 | 0.1932 | / |
| Multiple model | HL-C3535K9W3KA(Ra1)-FC | 800 | 2.34 | 2700-6500 | 1 | 800 | 410 | 0.1932 | / |
| Multiple model | HL-C3535F77W1KA(Ra1)-FC | 500 | 1.4 | 2700-6500 | 1 | 500 | 383 | 0.1176 | / |
| Multiple model | HL-C3535F77W1KA(Ra1)-FC-LVR | 500 | 1.4 | 2700-6500 | 1 | 500 | 383 | 0.1176 | / |

1.2 Standards and Reference Documentations

- ANSI/IES LM-80-15: IES Approved Method for Measuring Lumen Maintenance of LED Light Sources.
- CIE 127:2007: Measurement of LEDs
- ENERGY STAR[®] Requirements for the Use of LM-80 Data (This standard was not accredited by IAS)

1.3 Testing Equipment

| Device | Manufacture | Model No | Serial No | Calibration date | Calibration due date |
|---------------------------------------|-------------|-----------|------------------|------------------|----------------------|
| High Accuracy Array Spectroradiometer | EVERFINE | HAAS 2000 | P600674CM5391140 | 2021-09-27 | 2022-09-26 |
| 0.5M Integrating Sphere | EVERFINE | 0.5m | NA | 2021-09-27 | 2022-09-26 |
| LED Test Source | EVERFINE | LTS-300 | P185616CJ1391143 | 2022-01-05 | 2023-01-04 |
| Standard Light Source | EVERFINE | D062 | 1011093 | 2021-10-15 | 2022-10-14 |
| Multilayer aging machine | BACL | B2-270 | 20022 | 2021-02-24 | 2022-02-23 |
| Digital CC&CV DC Power Supply | EVERFINE | WY5015 | 11090009 | 2022-01-04 | 2023-01-03 |

1.4 Drive Level

Samples are driven with a constant direct current (DC) during maintenance test, photometric and electrical measurement. The current value was regulated to within $\pm 3\%$ of the specified value of the manufacturer during maintenance test, and was within $\pm 0.5\%$ during photometric and electrical measurement test.

1.5 Ambient Conditions for Maintenance Test

For lumen maintenance test, samples within one data set, were installed on cooling boards in thermal chambers with minimal ambient airflow. The case temperature and ambient temperature was monitored by thermocouples which one was soldered to the coldest DUTs' case (TMP_{LED}) location, while the other is mounted at a distance of 5 mm above the TMP location.

During life testing, TMP_{LED} of the coldest LEDs were maintained at a temperature that was greater than or equal to 2°C below the corresponding nominal case temperature. Surrounding air was maintained at a temperature that was greater than or equal to 5°C below the corresponding nominal case temperature. Thermocouples were shielded from direct DUT optical radiation and comply with ASTM E230 Table 1 "Special Limits".

Samples were connected to DC power supply in series circuits with a constant current. The forward current was regulated to within $\pm 3\%$ of the specified value of the manufacturer.

The relative humidity within chamber was kept less than 65% during test.

For photometry measurement, the ambient temperature during test was set to $25^{\circ}\text{C} \pm 2^{\circ}\text{C}$, RH <65%.

1.6 Photometric Measurement Method and Uncertainty

Integrating sphere and spectroradiometer is used to measure luminous flux and chromaticity coordinate $u'v'$. 2π measurement was used and sample was driven by DC power supply. The forward current was regulated to within $\pm 0.5\%$ of the nominal value. The test system was calibrated by halogen reference lamp. The ambient temperature during test was set to $25^{\circ}\text{C} \pm 2^{\circ}\text{C}$, RH <65%. The temperature measurement point was located in the sphere and the temperature was detected by a temperature probe.

The uncertainty of the light output measurements is $U=1.59\%$ ($K=2$), at the 95% confidence level. The uncertainty of the correlated color temperature measurements is $U=21\text{K}$ ($K=2$), at the 95% confidence level.

The uncertainty of the temperature is $U=0.8671^{\circ}\text{C}$ ($K=2$), at the 95% confidence level.

1.7 Statement of Traceability

Bay Area Compliance Laboratories Corp. (Dongguan) attested that all calibration has been performed using suitable standards traceable to National Primary Standards and International System of Units (SI).

1.8 Sample Set

Data Set 1: 55°C, 800mA

Part Number: HL-C3535K9W1EA(Ra1)-FC
Number of Units: 30
Case Temperature: $>53^{\circ}\text{C}$
Ambient Temperature: $>50^{\circ}\text{C}$
Life Test Drive Current: 800mA
Measurement Current: 800mA

Data Set 2: 105°C, 800mA

Part Number: HL-C3535K9W1EA(Ra1)-FC
Number of Units: 30
Case Temperature: $>103^{\circ}\text{C}$
Ambient Temperature: $>100^{\circ}\text{C}$
Life Test Drive Current: 800mA
Measurement Current: 800mA

2 - Summary of Test Result

| Data Set: | Sample Size | Failures Observed: | Test Interval | Test Duration | α | β | Reported TM-21 L ₇₀ Lifetime | Reported TM-21 L ₈₀ Lifetime | Reported TM-21 L ₉₀ Lifetime |
|-----------|-------------|--------------------|---------------|---------------|-----------|---------|---|---|---|
| 1 | 30 | 0 | 1000hrs | 10000hrs | 2.795E-06 | 1.005 | >60000 hours | >60000 hours | 40000 hours |
| 2 | 30 | 0 | 1000hrs | 10000hrs | 3.339E-06 | 1.005 | >60000 hours | >60000 hours | 33000 hours |

Average Lumen Maintenance (Percentage of Initial Luminous Flux)

| Data Set: | 1000hrs | 2000hrs | 3000hrs | 4000hrs | 5000hrs | 6000hrs | 7000hrs | 8000hrs | 9000hrs | 10000hrs |
|-----------|---------|---------|---------|---------|---------|---------|---------|---------|---------|----------|
| 1 | 100.29% | 99.95% | 99.68% | 99.38% | 99.11% | 98.87% | 98.56% | 98.28% | 98.02% | 97.75% |
| 2 | 100.09% | 99.72% | 99.44% | 99.11% | 98.79% | 98.49% | 98.14% | 97.81% | 97.50% | 97.16% |

Average Chromaticity Shift

| Data Set: | 1000hrs | 2000hrs | 3000hrs | 4000hrs | 5000hrs | 6000hrs | 7000hrs | 8000hrs | 9000hrs | 10000hrs |
|-----------|---------|---------|---------|---------|---------|---------|---------|---------|---------|----------|
| 1 | 0.0004 | 0.0004 | 0.0007 | 0.0007 | 0.0009 | 0.0011 | 0.0012 | 0.0014 | 0.0016 | 0.0018 |
| 2 | 0.0004 | 0.0005 | 0.0009 | 0.0006 | 0.0009 | 0.0012 | 0.0013 | 0.0015 | 0.0017 | 0.0019 |

Average Lumen Maintenance and Chromaticity Shift VS. Time

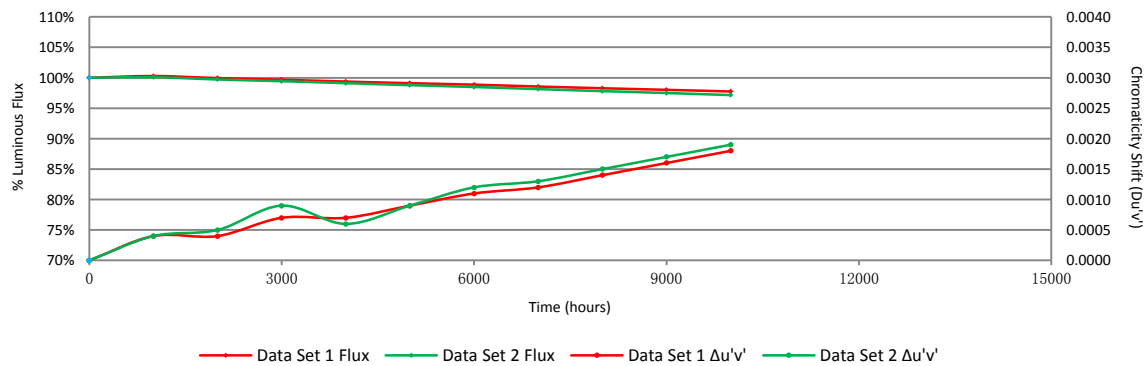

3 - Test Data

3.1 Data Set 1, 55°C, 800mA (Lumen Maintenance)

| No. | Φ(m) | Lumen Maintenance (%) | | | | | | | | | |
|--------|--------------|-----------------------|---------|---------|---------|---------|---------|---------|---------|---------|----------|
| | 0hr(Initial) | 1000hrs | 2000hrs | 3000hrs | 4000hrs | 5000hrs | 6000hrs | 7000hrs | 8000hrs | 9000hrs | 10000hrs |
| 1 | 338.80 | 100.32 | 99.94 | 99.76 | 99.32 | 99.17 | 99.03 | 99.00 | 98.70 | 98.47 | 98.14 |
| 2 | 333.70 | 100.30 | 100.18 | 99.88 | 99.58 | 99.22 | 99.01 | 98.89 | 98.68 | 98.35 | 98.05 |
| 3 | 335.80 | 100.21 | 99.97 | 99.64 | 99.43 | 99.08 | 98.90 | 98.51 | 98.33 | 98.12 | 97.83 |
| 4 | 336.80 | 100.24 | 99.94 | 99.61 | 99.41 | 99.20 | 98.90 | 98.57 | 98.31 | 98.04 | 97.74 |
| 5 | 335.60 | 100.39 | 100.09 | 99.70 | 99.34 | 99.20 | 99.02 | 98.75 | 98.51 | 98.33 | 98.09 |
| 6 | 335.30 | 100.39 | 100.15 | 99.76 | 99.61 | 99.25 | 99.05 | 98.42 | 98.18 | 97.88 | 97.73 |
| 7 | 338.00 | 100.65 | 100.38 | 99.88 | 99.70 | 99.56 | 99.26 | 99.17 | 98.85 | 98.58 | 98.25 |
| 8 | 334.90 | 100.36 | 100.00 | 99.64 | 99.40 | 99.04 | 98.84 | 98.66 | 98.45 | 98.27 | 97.97 |
| 9 | 336.50 | 100.45 | 100.09 | 99.70 | 99.41 | 99.20 | 98.90 | 98.75 | 98.57 | 98.34 | 98.13 |
| 10 | 335.00 | 100.33 | 100.03 | 99.91 | 99.49 | 99.19 | 98.75 | 98.51 | 98.15 | 97.88 | 97.61 |
| 11 | 336.90 | 100.42 | 100.27 | 100.09 | 99.82 | 99.53 | 99.23 | 98.69 | 98.46 | 98.10 | 97.92 |
| 12 | 337.10 | 100.39 | 100.15 | 100.00 | 99.85 | 99.58 | 99.35 | 99.05 | 98.69 | 98.52 | 98.16 |
| 13 | 335.10 | 100.18 | 100.03 | 99.82 | 99.67 | 99.34 | 99.07 | 98.96 | 98.66 | 98.36 | 98.06 |
| 14 | 327.40 | 100.37 | 99.88 | 99.85 | 99.39 | 99.14 | 98.93 | 98.72 | 98.35 | 98.05 | 97.83 |
| 15 | 326.70 | 100.37 | 100.15 | 99.88 | 99.63 | 99.45 | 99.27 | 98.90 | 98.71 | 98.50 | 98.26 |
| 16 | 331.80 | 100.30 | 99.94 | 99.91 | 99.34 | 99.13 | 98.88 | 98.25 | 97.98 | 97.65 | 97.41 |
| 17 | 336.70 | 100.27 | 99.82 | 99.73 | 99.20 | 98.96 | 98.84 | 98.60 | 98.25 | 97.95 | 97.68 |
| 18 | 337.80 | 100.33 | 99.85 | 99.67 | 99.41 | 99.14 | 98.76 | 98.58 | 98.31 | 97.96 | 97.72 |
| 19 | 342.80 | 100.18 | 99.91 | 99.39 | 99.12 | 98.83 | 98.72 | 98.31 | 97.93 | 97.70 | 97.37 |
| 20 | 333.00 | 100.09 | 99.88 | 99.43 | 99.13 | 98.95 | 98.68 | 98.38 | 98.11 | 97.90 | 97.66 |
| 21 | 335.50 | 100.36 | 99.88 | 99.79 | 99.28 | 98.96 | 98.75 | 98.54 | 98.33 | 98.03 | 97.70 |
| 22 | 337.00 | 100.21 | 99.73 | 99.58 | 99.29 | 98.96 | 98.75 | 98.37 | 98.04 | 97.86 | 97.60 |
| 23 | 336.90 | 100.27 | 99.85 | 99.38 | 99.20 | 98.96 | 98.78 | 98.19 | 97.86 | 97.63 | 97.30 |
| 24 | 339.00 | 100.24 | 99.79 | 99.35 | 99.09 | 98.73 | 98.58 | 98.29 | 98.02 | 97.67 | 97.37 |
| 25 | 338.20 | 100.03 | 99.67 | 99.32 | 98.99 | 98.67 | 98.37 | 97.87 | 97.46 | 97.28 | 97.07 |
| 26 | 337.10 | 100.33 | 100.12 | 99.44 | 99.26 | 98.99 | 98.75 | 98.43 | 98.22 | 97.95 | 97.72 |
| 27 | 335.20 | 100.30 | 99.85 | 99.52 | 99.31 | 99.05 | 98.78 | 98.33 | 98.06 | 97.76 | 97.49 |
| 28 | 337.40 | 100.27 | 99.73 | 99.61 | 99.29 | 99.02 | 98.67 | 98.34 | 97.98 | 97.81 | 97.60 |
| 29 | 338.80 | 100.18 | 99.73 | 99.53 | 99.35 | 99.03 | 98.76 | 98.52 | 98.23 | 97.90 | 97.67 |
| 30 | 333.70 | 100.06 | 99.55 | 99.46 | 98.98 | 98.68 | 98.50 | 98.23 | 98.08 | 97.84 | 97.39 |
| Avg. | 335.82 | 100.29 | 99.95 | 99.68 | 99.38 | 99.11 | 98.87 | 98.56 | 98.28 | 98.02 | 97.75 |
| Med. | 336.60 | 100.30 | 99.94 | 99.69 | 99.35 | 99.10 | 98.84 | 98.53 | 98.28 | 97.96 | 97.72 |
| st dev | 3.18 | 0.12 | 0.19 | 0.21 | 0.22 | 0.23 | 0.23 | 0.29 | 0.31 | 0.31 | 0.31 |
| Min. | 326.70 | 100.03 | 99.55 | 99.32 | 98.98 | 98.67 | 98.37 | 97.87 | 97.46 | 97.28 | 97.07 |
| Max. | 342.80 | 100.65 | 100.38 | 100.09 | 99.85 | 99.58 | 99.35 | 99.17 | 98.85 | 98.58 | 98.26 |

3.2 Data Set 1, 55°C, 800mA (Forward Voltage)

| No. | Forward Voltage (V) | | | | | | | | | | |
|--------|---------------------|---------|---------|---------|---------|---------|---------|---------|---------|---------|----------|
| | Ohr(Initial) | 1000hrs | 2000hrs | 3000hrs | 4000hrs | 5000hrs | 6000hrs | 7000hrs | 8000hrs | 9000hrs | 10000hrs |
| 1 | 2.910 | 2.927 | 2.928 | 2.921 | 2.911 | 2.924 | 2.928 | 2.926 | 2.933 | 2.944 | 2.930 |
| 2 | 2.920 | 2.939 | 2.939 | 2.936 | 2.958 | 2.961 | 2.957 | 2.955 | 2.955 | 2.929 | 2.937 |
| 3 | 2.907 | 2.923 | 2.922 | 2.921 | 2.917 | 2.929 | 2.932 | 2.914 | 2.930 | 2.925 | 2.924 |
| 4 | 2.908 | 2.923 | 2.923 | 2.917 | 2.916 | 2.947 | 2.930 | 2.922 | 2.938 | 2.928 | 2.938 |
| 5 | 2.925 | 2.931 | 2.932 | 2.934 | 2.935 | 2.948 | 2.937 | 2.934 | 2.928 | 2.923 | 2.931 |
| 6 | 2.922 | 2.935 | 2.940 | 2.931 | 2.943 | 2.922 | 2.921 | 2.918 | 2.925 | 2.920 | 2.931 |
| 7 | 2.924 | 2.939 | 2.938 | 2.944 | 2.930 | 2.931 | 2.940 | 2.935 | 2.931 | 2.942 | 2.938 |
| 8 | 2.925 | 2.936 | 2.935 | 2.927 | 2.935 | 2.952 | 2.936 | 2.937 | 2.937 | 2.936 | 2.944 |
| 9 | 2.919 | 2.939 | 2.936 | 2.942 | 2.947 | 2.937 | 2.936 | 2.938 | 2.941 | 2.937 | 2.936 |
| 10 | 2.920 | 2.936 | 2.933 | 2.934 | 2.934 | 2.952 | 2.958 | 2.944 | 2.922 | 2.924 | 2.940 |
| 11 | 2.926 | 2.941 | 2.939 | 2.935 | 2.943 | 2.945 | 2.941 | 2.938 | 2.931 | 2.927 | 2.920 |
| 12 | 2.917 | 2.933 | 2.934 | 2.931 | 2.931 | 2.957 | 2.952 | 2.942 | 2.930 | 2.923 | 2.936 |
| 13 | 2.903 | 2.925 | 2.923 | 2.928 | 2.927 | 2.926 | 2.926 | 2.921 | 2.928 | 2.922 | 2.930 |
| 14 | 2.916 | 2.932 | 2.933 | 2.925 | 2.934 | 2.947 | 2.952 | 2.945 | 2.947 | 2.926 | 2.936 |
| 15 | 2.906 | 2.920 | 2.919 | 2.913 | 2.927 | 2.908 | 2.926 | 2.921 | 2.925 | 2.931 | 2.920 |
| 16 | 2.914 | 2.931 | 2.928 | 2.923 | 2.933 | 2.937 | 2.939 | 2.935 | 2.925 | 2.928 | 2.952 |
| 17 | 2.919 | 2.934 | 2.933 | 2.923 | 2.947 | 2.948 | 2.937 | 2.942 | 2.934 | 2.925 | 2.927 |
| 18 | 2.915 | 2.930 | 2.930 | 2.920 | 2.926 | 2.917 | 2.927 | 2.955 | 2.938 | 2.924 | 2.926 |
| 19 | 2.929 | 2.945 | 2.943 | 2.934 | 2.936 | 2.941 | 2.945 | 2.948 | 2.925 | 2.910 | 2.921 |
| 20 | 2.904 | 2.916 | 2.915 | 2.908 | 2.917 | 2.921 | 2.930 | 2.906 | 2.921 | 2.919 | 2.945 |
| 21 | 2.926 | 2.941 | 2.939 | 2.928 | 2.928 | 2.924 | 2.928 | 2.933 | 2.926 | 2.927 | 2.925 |
| 22 | 2.919 | 2.933 | 2.932 | 2.922 | 2.916 | 2.931 | 2.928 | 2.911 | 2.919 | 2.928 | 2.929 |
| 23 | 2.919 | 2.933 | 2.933 | 2.925 | 2.920 | 2.943 | 2.931 | 2.910 | 2.921 | 2.929 | 2.928 |
| 24 | 2.929 | 2.946 | 2.944 | 2.946 | 2.936 | 2.926 | 2.926 | 2.927 | 2.925 | 2.921 | 2.921 |
| 25 | 2.929 | 2.947 | 2.944 | 2.947 | 2.939 | 2.946 | 2.941 | 2.927 | 2.922 | 2.926 | 2.927 |
| 26 | 2.919 | 2.932 | 2.931 | 2.927 | 2.919 | 2.915 | 2.921 | 2.913 | 2.919 | 2.918 | 2.916 |
| 27 | 2.917 | 2.933 | 2.934 | 2.923 | 2.919 | 2.937 | 2.920 | 2.913 | 2.919 | 2.921 | 2.925 |
| 28 | 2.917 | 2.934 | 2.934 | 2.923 | 2.919 | 2.929 | 2.909 | 2.915 | 2.921 | 2.922 | 2.928 |
| 29 | 2.902 | 2.918 | 2.915 | 2.906 | 2.916 | 2.925 | 2.929 | 2.927 | 2.927 | 2.937 | 2.938 |
| 30 | 2.906 | 2.921 | 2.922 | 2.913 | 2.917 | 2.926 | 2.924 | 2.929 | 2.925 | 2.942 | 2.938 |
| Avg. | 2.917 | 2.932 | 2.932 | 2.927 | 2.929 | 2.935 | 2.934 | 2.929 | 2.929 | 2.927 | 2.931 |
| Med. | 2.919 | 2.933 | 2.933 | 2.926 | 2.929 | 2.934 | 2.931 | 2.928 | 2.927 | 2.926 | 2.930 |
| st dev | 0.008 | 0.008 | 0.008 | 0.010 | 0.012 | 0.013 | 0.011 | 0.014 | 0.009 | 0.008 | 0.008 |
| Min. | 2.902 | 2.916 | 2.915 | 2.906 | 2.911 | 2.908 | 2.909 | 2.906 | 2.919 | 2.910 | 2.916 |
| Max. | 2.929 | 2.947 | 2.944 | 2.947 | 2.958 | 2.961 | 2.958 | 2.955 | 2.955 | 2.944 | 2.952 |

3.3 Data Set 1, 55°C, 800mA (Chromaticity Shift)

| No. | u' | v' | CCT(K) | Chromaticity Shift ($\Delta u'v'$) | | | | | | | | | |
|--------|--------|--------|--------|--------------------------------------|---------|---------|---------|---------|---------|---------|---------|---------|---------|
| | | | | Ohr(Initial) | 1000hrs | 2000hrs | 3000hrs | 4000hrs | 5000hrs | 6000hrs | 7000hrs | 8000hrs | 9000hrs |
| 1 | 0.2569 | 0.5219 | 54 | 0.0003 | 0.0003 | 0.0011 | 0.0011 | 0.0013 | 0.0013 | 0.0011 | 0.0013 | 0.0014 | 0.0017 |
| 2 | 0.2590 | 0.5271 | 60 | 0.0004 | 0.0005 | 0.0007 | 0.0007 | 0.0008 | 0.0011 | 0.0011 | 0.0012 | 0.0013 | 0.0014 |
| 3 | 0.2604 | 0.5281 | 62 | 0.0006 | 0.0006 | 0.0006 | 0.0006 | 0.0008 | 0.0009 | 0.0011 | 0.0014 | 0.0017 | 0.0018 |
| 4 | 0.2565 | 0.5225 | 2853 | 0.0004 | 0.0004 | 0.0006 | 0.0006 | 0.0009 | 0.0010 | 0.0013 | 0.0014 | 0.0016 | 0.0018 |
| 5 | 0.2592 | 0.5265 | 2773 | 0.0003 | 0.0004 | 0.0009 | 0.0009 | 0.0010 | 0.0012 | 0.0015 | 0.0018 | 0.0019 | 0.0022 |
| 6 | 0.2586 | 0.5264 | 2787 | 0.0004 | 0.0005 | 0.0006 | 0.0006 | 0.0007 | 0.0009 | 0.0011 | 0.0014 | 0.0016 | 0.0017 |
| 7 | 0.2580 | 0.5284 | 2790 | 0.0004 | 0.0005 | 0.0007 | 0.0007 | 0.0009 | 0.0010 | 0.0012 | 0.0014 | 0.0016 | 0.0019 |
| 8 | 0.2594 | 0.5253 | 2774 | 0.0004 | 0.0005 | 0.0006 | 0.0006 | 0.0008 | 0.0009 | 0.0011 | 0.0013 | 0.0015 | 0.0016 |
| 9 | 0.2572 | 0.5223 | 2838 | 0.0003 | 0.0004 | 0.0008 | 0.0008 | 0.0010 | 0.0010 | 0.0014 | 0.0015 | 0.0017 | 0.0020 |
| 10 | 0.2591 | 0.5282 | 2768 | 0.0004 | 0.0004 | 0.0008 | 0.0008 | 0.0010 | 0.0011 | 0.0014 | 0.0016 | 0.0017 | 0.0019 |
| 11 | 0.2601 | 0.5295 | 2741 | 0.0004 | 0.0005 | 0.0006 | 0.0006 | 0.0008 | 0.0011 | 0.0012 | 0.0015 | 0.0016 | 0.0017 |
| 12 | 0.2588 | 0.5266 | 2781 | 0.0005 | 0.0005 | 0.0006 | 0.0006 | 0.0009 | 0.0011 | 0.0011 | 0.0013 | 0.0015 | 0.0016 |
| 13 | 0.2601 | 0.5259 | 2756 | 0.0003 | 0.0004 | 0.0008 | 0.0008 | 0.0009 | 0.0011 | 0.0012 | 0.0013 | 0.0015 | 0.0016 |
| 14 | 0.2567 | 0.5234 | 2843 | 0.0004 | 0.0005 | 0.0005 | 0.0005 | 0.0008 | 0.0010 | 0.0013 | 0.0015 | 0.0017 | 0.0018 |
| 15 | 0.2596 | 0.5275 | 2761 | 0.0004 | 0.0004 | 0.0006 | 0.0006 | 0.0008 | 0.0010 | 0.0011 | 0.0013 | 0.0016 | 0.0017 |
| 16 | 0.2624 | 0.5304 | 2689 | 0.0004 | 0.0004 | 0.0007 | 0.0007 | 0.0009 | 0.0011 | 0.0011 | 0.0013 | 0.0016 | 0.0018 |
| 17 | 0.2589 | 0.5253 | 2786 | 0.0004 | 0.0005 | 0.0008 | 0.0008 | 0.0011 | 0.0013 | 0.0015 | 0.0016 | 0.0018 | 0.0021 |
| 18 | 0.2593 | 0.5288 | 2760 | 0.0004 | 0.0004 | 0.0008 | 0.0008 | 0.0011 | 0.0011 | 0.0014 | 0.0016 | 0.0017 | 0.0018 |
| 19 | 0.2593 | 0.5279 | 2764 | 0.0004 | 0.0004 | 0.0007 | 0.0007 | 0.0010 | 0.0012 | 0.0012 | 0.0015 | 0.0016 | 0.0018 |
| 20 | 0.2577 | 0.5234 | 2821 | 0.0004 | 0.0004 | 0.0008 | 0.0008 | 0.0009 | 0.0011 | 0.0013 | 0.0015 | 0.0017 | 0.0019 |
| 21 | 0.2595 | 0.5248 | 2774 | 0.0004 | 0.0003 | 0.0007 | 0.0007 | 0.0010 | 0.0012 | 0.0014 | 0.0015 | 0.0017 | 0.0018 |
| 22 | 0.2572 | 0.5225 | 2837 | 0.0004 | 0.0006 | 0.0005 | 0.0005 | 0.0008 | 0.0008 | 0.0011 | 0.0013 | 0.0016 | 0.0018 |
| 23 | 0.2601 | 0.5276 | 2748 | 0.0003 | 0.0004 | 0.0006 | 0.0006 | 0.0009 | 0.0011 | 0.0010 | 0.0012 | 0.0015 | 0.0017 |
| 24 | 0.2600 | 0.5307 | 2739 | 0.0003 | 0.0004 | 0.0006 | 0.0006 | 0.0008 | 0.0013 | 0.0011 | 0.0014 | 0.0015 | 0.0018 |
| 25 | 0.2595 | 0.5268 | 2766 | 0.0004 | 0.0004 | 0.0005 | 0.0005 | 0.0008 | 0.0012 | 0.0012 | 0.0014 | 0.0016 | 0.0018 |
| 26 | 0.2601 | 0.5279 | 2749 | 0.0003 | 0.0004 | 0.0006 | 0.0006 | 0.0008 | 0.0011 | 0.0014 | 0.0015 | 0.0016 | 0.0018 |
| 27 | 0.2599 | 0.5245 | 2768 | 0.0004 | 0.0004 | 0.0009 | 0.0009 | 0.0011 | 0.0012 | 0.0014 | 0.0015 | 0.0017 | 0.0020 |
| 28 | 0.2575 | 0.5237 | 2823 | 0.0005 | 0.0005 | 0.0006 | 0.0006 | 0.0008 | 0.0011 | 0.0013 | 0.0016 | 0.0017 | 0.0018 |
| 29 | 0.2588 | 0.5272 | 2778 | 0.0004 | 0.0005 | 0.0006 | 0.0006 | 0.0009 | 0.0011 | 0.0013 | 0.0016 | 0.0018 | 0.0019 |
| 30 | 0.2606 | 0.5269 | 2742 | 0.0004 | 0.0004 | 0.0009 | 0.0009 | 0.0012 | 0.0013 | 0.0014 | 0.0017 | 0.0018 | 0.0020 |
| Avg. | 0.2590 | 0.5263 | 2506 | 0.0004 | 0.0004 | 0.0007 | 0.0007 | 0.0009 | 0.0011 | 0.0012 | 0.0014 | 0.0016 | 0.0018 |
| Med. | 0.2593 | 0.5267 | 2768 | 0.0004 | 0.0004 | 0.0007 | 0.0007 | 0.0009 | 0.0011 | 0.0012 | 0.0015 | 0.0016 | 0.0018 |
| st dev | 0.0013 | 0.0024 | 831 | 0.0001 | 0.0001 | 0.0001 | 0.0001 | 0.0001 | 0.0001 | 0.0001 | 0.0001 | 0.0001 | 0.0002 |
| Min. | 0.2565 | 0.5219 | 54 | 0.0003 | 0.0003 | 0.0005 | 0.0005 | 0.0007 | 0.0008 | 0.0010 | 0.0012 | 0.0013 | 0.0014 |
| Max. | 0.2624 | 0.5307 | 2853 | 0.0006 | 0.0006 | 0.0011 | 0.0011 | 0.0013 | 0.0013 | 0.0015 | 0.0018 | 0.0019 | 0.0022 |

3.4 Data Set 2, 105°C, 800mA (Lumen Maintenance)

| No. | Φ(lm) | Lumen Maintenance (%) | | | | | | | | | |
|--------|--------------|-----------------------|---------|---------|---------|---------|---------|---------|---------|---------|----------|
| | 0hr(Initial) | 1000hrs | 2000hrs | 3000hrs | 4000hrs | 5000hrs | 6000hrs | 7000hrs | 8000hrs | 9000hrs | 10000hrs |
| 31 | 338.30 | 100.12 | 99.70 | 99.53 | 99.05 | 98.67 | 98.40 | 98.02 | 97.55 | 97.31 | 96.93 |
| 32 | 333.10 | 100.21 | 99.88 | 99.73 | 99.19 | 98.89 | 98.65 | 98.08 | 97.72 | 97.33 | 97.00 |
| 33 | 334.10 | 99.97 | 99.67 | 99.37 | 99.04 | 98.65 | 98.32 | 97.79 | 97.61 | 97.31 | 97.04 |
| 34 | 336.10 | 100.15 | 99.73 | 99.43 | 99.11 | 98.72 | 98.45 | 98.07 | 97.86 | 97.53 | 97.08 |
| 35 | 337.40 | 100.09 | 99.73 | 99.41 | 99.26 | 98.96 | 98.58 | 98.37 | 98.01 | 97.66 | 97.33 |
| 36 | 333.30 | 100.15 | 99.76 | 99.37 | 99.10 | 98.83 | 98.59 | 98.38 | 98.11 | 97.75 | 97.36 |
| 37 | 335.80 | 100.03 | 99.94 | 99.76 | 99.37 | 99.05 | 98.75 | 98.72 | 98.36 | 98.00 | 97.71 |
| 38 | 335.70 | 100.09 | 99.79 | 99.70 | 99.31 | 99.05 | 98.78 | 98.66 | 98.42 | 98.09 | 97.83 |
| 39 | 334.00 | 100.12 | 99.70 | 99.61 | 99.19 | 98.86 | 98.65 | 98.41 | 98.05 | 97.78 | 97.46 |
| 40 | 336.70 | 99.97 | 99.61 | 99.20 | 98.87 | 98.57 | 98.34 | 97.98 | 97.62 | 97.33 | 96.97 |
| 41 | 334.20 | 100.12 | 99.34 | 99.19 | 98.86 | 98.50 | 98.11 | 97.64 | 97.19 | 96.98 | 96.77 |
| 42 | 335.50 | 100.12 | 99.52 | 99.25 | 98.96 | 98.63 | 98.39 | 98.03 | 97.73 | 97.44 | 97.11 |
| 43 | 337.20 | 100.06 | 99.70 | 99.38 | 99.17 | 98.96 | 98.72 | 98.55 | 98.10 | 97.84 | 97.39 |
| 44 | 340.10 | 99.91 | 99.71 | 99.38 | 99.15 | 98.85 | 98.53 | 98.41 | 98.15 | 97.74 | 97.41 |
| 45 | 339.90 | 100.09 | 99.74 | 99.56 | 99.12 | 98.79 | 98.59 | 98.00 | 97.68 | 97.32 | 96.91 |
| 46 | 334.60 | 100.15 | 99.76 | 99.52 | 99.31 | 99.04 | 98.66 | 98.09 | 97.79 | 97.52 | 97.22 |
| 47 | 336.70 | 100.18 | 99.82 | 99.55 | 99.23 | 98.96 | 98.60 | 98.37 | 97.89 | 97.56 | 97.27 |
| 48 | 339.00 | 100.32 | 99.85 | 99.56 | 99.32 | 99.09 | 98.64 | 98.20 | 97.94 | 97.67 | 97.26 |
| 49 | 338.90 | 100.24 | 99.97 | 99.44 | 99.06 | 98.67 | 98.29 | 98.20 | 97.93 | 97.46 | 97.14 |
| 50 | 336.60 | 100.03 | 99.70 | 99.05 | 98.75 | 98.46 | 98.10 | 97.65 | 97.30 | 96.91 | 96.52 |
| 51 | 335.00 | 100.18 | 99.85 | 99.76 | 99.19 | 98.93 | 98.63 | 97.94 | 97.61 | 97.37 | 97.01 |
| 52 | 336.90 | 100.06 | 99.76 | 99.61 | 99.20 | 98.75 | 98.46 | 97.98 | 97.80 | 97.48 | 97.12 |
| 53 | 334.00 | 100.27 | 99.70 | 99.52 | 99.10 | 98.71 | 98.44 | 98.29 | 97.99 | 97.60 | 97.31 |
| 54 | 332.90 | 100.06 | 99.67 | 99.43 | 99.16 | 98.86 | 98.56 | 98.20 | 97.84 | 97.54 | 97.27 |
| 55 | 337.90 | 100.03 | 99.70 | 99.44 | 99.14 | 98.76 | 98.37 | 97.93 | 97.45 | 97.10 | 96.89 |
| 56 | 332.80 | 100.03 | 99.76 | 99.43 | 99.16 | 98.95 | 98.65 | 98.38 | 98.17 | 97.96 | 97.63 |
| 57 | 335.10 | 99.97 | 99.70 | 99.40 | 98.99 | 98.63 | 98.27 | 97.85 | 97.55 | 97.19 | 96.87 |
| 58 | 337.40 | 99.97 | 99.70 | 99.41 | 99.08 | 98.87 | 98.61 | 98.10 | 97.81 | 97.60 | 97.24 |
| 59 | 336.20 | 99.88 | 99.55 | 99.20 | 98.87 | 98.51 | 98.22 | 97.71 | 97.35 | 97.06 | 96.79 |
| 60 | 337.50 | 100.06 | 99.50 | 99.05 | 98.87 | 98.49 | 98.37 | 98.16 | 97.84 | 97.45 | 97.04 |
| Avg. | 336.10 | 100.09 | 99.72 | 99.44 | 99.11 | 98.79 | 98.49 | 98.14 | 97.81 | 97.50 | 97.16 |
| Med. | 336.15 | 100.09 | 99.71 | 99.43 | 99.13 | 98.81 | 98.54 | 98.10 | 97.82 | 97.50 | 97.13 |
| st dev | 2.05 | 0.10 | 0.13 | 0.19 | 0.15 | 0.18 | 0.18 | 0.28 | 0.30 | 0.29 | 0.29 |
| Min. | 332.80 | 99.88 | 99.34 | 99.05 | 98.75 | 98.46 | 98.10 | 97.64 | 97.19 | 96.91 | 96.52 |
| Max. | 340.10 | 100.32 | 99.97 | 99.76 | 99.37 | 99.09 | 98.78 | 98.72 | 98.42 | 98.09 | 97.83 |

3.5 Data Set 2, 105°C, 800mA (Forward Voltage)

| No. | Forward Voltage (V) | | | | | | | | | | |
|--------|---------------------|---------|---------|---------|---------|---------|---------|---------|---------|---------|----------|
| | Ohr(Initial) | 1000hrs | 2000hrs | 3000hrs | 4000hrs | 5000hrs | 6000hrs | 7000hrs | 8000hrs | 9000hrs | 10000hrs |
| 31 | 2.926 | 2.942 | 2.940 | 2.931 | 2.938 | 2.933 | 2.947 | 2.928 | 2.938 | 2.926 | 2.932 |
| 32 | 2.922 | 2.935 | 2.933 | 2.925 | 2.936 | 2.930 | 2.944 | 2.926 | 2.924 | 2.928 | 2.927 |
| 33 | 2.914 | 2.930 | 2.928 | 2.921 | 2.932 | 2.930 | 2.930 | 2.925 | 2.923 | 2.928 | 2.921 |
| 34 | 2.929 | 2.942 | 2.941 | 2.931 | 2.947 | 2.924 | 2.945 | 2.926 | 2.929 | 2.928 | 2.925 |
| 35 | 2.925 | 2.944 | 2.943 | 2.930 | 2.943 | 2.941 | 2.942 | 2.923 | 2.926 | 2.924 | 2.924 |
| 36 | 2.922 | 2.936 | 2.935 | 2.923 | 2.935 | 2.933 | 2.926 | 2.917 | 2.926 | 2.927 | 2.946 |
| 37 | 2.903 | 2.920 | 2.919 | 2.910 | 2.921 | 2.937 | 2.930 | 2.915 | 2.913 | 2.921 | 2.939 |
| 38 | 2.913 | 2.928 | 2.928 | 2.922 | 2.921 | 2.912 | 2.923 | 2.928 | 2.938 | 2.951 | 2.942 |
| 39 | 2.928 | 2.922 | 2.921 | 2.915 | 2.924 | 2.934 | 2.925 | 2.926 | 2.928 | 2.934 | 2.938 |
| 40 | 2.919 | 2.933 | 2.934 | 2.932 | 2.944 | 2.944 | 2.925 | 2.923 | 2.923 | 2.942 | 2.932 |
| 41 | 2.917 | 2.932 | 2.932 | 2.925 | 2.943 | 2.934 | 2.947 | 2.917 | 2.913 | 2.937 | 2.938 |
| 42 | 2.924 | 2.936 | 2.935 | 2.928 | 2.925 | 2.935 | 2.938 | 2.924 | 2.920 | 2.942 | 2.932 |
| 43 | 2.915 | 2.932 | 2.933 | 2.927 | 2.920 | 2.933 | 2.934 | 2.921 | 2.917 | 2.937 | 2.920 |
| 44 | 2.928 | 2.947 | 2.949 | 2.935 | 2.939 | 2.925 | 2.940 | 2.930 | 2.928 | 2.924 | 2.924 |
| 45 | 2.929 | 2.946 | 2.943 | 2.936 | 2.928 | 2.943 | 2.958 | 2.923 | 2.924 | 2.923 | 2.925 |
| 46 | 2.903 | 2.934 | 2.916 | 2.912 | 2.916 | 2.917 | 2.926 | 2.896 | 2.915 | 2.940 | 2.922 |
| 47 | 2.922 | 2.940 | 2.939 | 2.929 | 2.928 | 2.948 | 2.954 | 2.914 | 2.913 | 2.926 | 2.928 |
| 48 | 2.924 | 2.942 | 2.940 | 2.935 | 2.937 | 2.957 | 2.956 | 2.920 | 2.929 | 2.922 | 2.921 |
| 49 | 2.924 | 2.942 | 2.943 | 2.935 | 2.949 | 2.946 | 2.952 | 2.919 | 2.919 | 2.926 | 2.933 |
| 50 | 2.914 | 2.932 | 2.931 | 2.924 | 2.929 | 2.959 | 2.946 | 2.915 | 2.915 | 2.938 | 2.921 |
| 51 | 2.913 | 2.932 | 2.930 | 2.922 | 2.912 | 2.925 | 2.946 | 2.918 | 2.910 | 2.922 | 2.921 |
| 52 | 2.915 | 2.933 | 2.932 | 2.925 | 2.918 | 2.940 | 2.932 | 2.932 | 2.922 | 2.939 | 2.928 |
| 53 | 2.909 | 2.920 | 2.919 | 2.912 | 2.924 | 2.927 | 2.947 | 2.900 | 2.921 | 2.924 | 2.922 |
| 54 | 2.906 | 2.923 | 2.926 | 2.918 | 2.925 | 2.920 | 2.938 | 2.913 | 2.927 | 2.924 | 2.925 |
| 55 | 2.917 | 2.934 | 2.935 | 2.930 | 2.935 | 2.943 | 2.964 | 2.925 | 2.928 | 2.943 | 2.928 |
| 56 | 2.902 | 2.917 | 2.916 | 2.911 | 2.914 | 2.923 | 2.960 | 2.921 | 2.926 | 2.927 | 2.946 |
| 57 | 2.905 | 2.920 | 2.919 | 2.914 | 2.930 | 2.930 | 2.931 | 2.909 | 2.925 | 2.924 | 2.944 |
| 58 | 2.904 | 2.920 | 2.919 | 2.915 | 2.923 | 2.935 | 2.969 | 2.912 | 2.926 | 2.922 | 2.925 |
| 59 | 2.913 | 2.931 | 2.928 | 2.922 | 2.921 | 2.934 | 2.964 | 2.920 | 2.918 | 2.932 | 2.924 |
| 60 | 2.915 | 2.935 | 2.933 | 2.926 | 2.936 | 2.960 | 2.957 | 2.917 | 2.912 | 2.935 | 2.936 |
| Avg. | 2.917 | 2.933 | 2.931 | 2.924 | 2.930 | 2.935 | 2.943 | 2.919 | 2.923 | 2.931 | 2.930 |
| Med. | 2.916 | 2.933 | 2.933 | 2.925 | 2.929 | 2.934 | 2.945 | 2.921 | 2.924 | 2.928 | 2.928 |
| st dev | 0.008 | 0.008 | 0.009 | 0.008 | 0.010 | 0.012 | 0.013 | 0.008 | 0.007 | 0.008 | 0.008 |
| Min. | 2.902 | 2.917 | 2.916 | 2.910 | 2.912 | 2.912 | 2.923 | 2.896 | 2.910 | 2.921 | 2.920 |
| Max. | 2.929 | 2.947 | 2.949 | 2.936 | 2.949 | 2.960 | 2.969 | 2.932 | 2.938 | 2.951 | 2.946 |

3.6 Data Set 2, 105°C, 800mA (Chromaticity Shift)

| No. | u' | v' | CCT(K) | Chromaticity Shift ($\Delta u'v'$) | | | | | | | | | |
|--------|--------|--------|--------|--------------------------------------|---------|---------|---------|---------|---------|---------|---------|---------|---------|
| | | | | Ohr(Initial) | 1000hrs | 2000hrs | 3000hrs | 4000hrs | 5000hrs | 6000hrs | 7000hrs | 8000hrs | 9000hrs |
| 31 | 0.2594 | 0.5285 | 2760 | 0.0004 | 0.0005 | 0.0009 | 0.0006 | 0.0010 | 0.0012 | 0.0012 | 0.0014 | 0.0015 | 0.0017 |
| 32 | 0.2594 | 0.5235 | 2782 | 0.0004 | 0.0005 | 0.0009 | 0.0006 | 0.0010 | 0.0011 | 0.0013 | 0.0014 | 0.0015 | 0.0017 |
| 33 | 0.2604 | 0.5252 | 2754 | 0.0004 | 0.0005 | 0.0009 | 0.0006 | 0.0009 | 0.0012 | 0.0013 | 0.0014 | 0.0015 | 0.0018 |
| 34 | 0.2596 | 0.5284 | 2756 | 0.0004 | 0.0006 | 0.0008 | 0.0005 | 0.0007 | 0.0010 | 0.0011 | 0.0013 | 0.0014 | 0.0016 |
| 35 | 0.2598 | 0.5286 | 2751 | 0.0004 | 0.0006 | 0.0007 | 0.0005 | 0.0007 | 0.0011 | 0.0011 | 0.0012 | 0.0014 | 0.0015 |
| 36 | 0.2597 | 0.5269 | 2761 | 0.0004 | 0.0005 | 0.0008 | 0.0006 | 0.0008 | 0.0012 | 0.0012 | 0.0014 | 0.0016 | 0.0017 |
| 37 | 0.2595 | 0.5268 | 2767 | 0.0003 | 0.0005 | 0.0011 | 0.0006 | 0.0009 | 0.0014 | 0.0013 | 0.0016 | 0.0018 | 0.0019 |
| 38 | 0.2580 | 0.5229 | 2816 | 0.0003 | 0.0004 | 0.0010 | 0.0009 | 0.0011 | 0.0014 | 0.0015 | 0.0016 | 0.0017 | 0.0020 |
| 39 | 0.2612 | 0.5259 | 2732 | 0.0004 | 0.0005 | 0.0008 | 0.0007 | 0.0009 | 0.0011 | 0.0013 | 0.0015 | 0.0016 | 0.0017 |
| 40 | 0.2587 | 0.5272 | 2782 | 0.0003 | 0.0005 | 0.0010 | 0.0006 | 0.0009 | 0.0012 | 0.0013 | 0.0016 | 0.0017 | 0.0019 |
| 41 | 0.2606 | 0.5278 | 2738 | 0.0004 | 0.0006 | 0.0009 | 0.0006 | 0.0008 | 0.0011 | 0.0013 | 0.0015 | 0.0017 | 0.0018 |
| 42 | 0.2606 | 0.5288 | 2734 | 0.0004 | 0.0005 | 0.0008 | 0.0004 | 0.0006 | 0.0010 | 0.0012 | 0.0013 | 0.0015 | 0.0017 |
| 43 | 0.2609 | 0.5293 | 2726 | 0.0005 | 0.0006 | 0.0009 | 0.0004 | 0.0008 | 0.0010 | 0.0010 | 0.0014 | 0.0015 | 0.0017 |
| 44 | 0.2593 | 0.5265 | 2772 | 0.0003 | 0.0004 | 0.0010 | 0.0006 | 0.0010 | 0.0012 | 0.0013 | 0.0016 | 0.0018 | 0.0021 |
| 45 | 0.2578 | 0.5266 | 2803 | 0.0004 | 0.0005 | 0.0008 | 0.0006 | 0.0009 | 0.0010 | 0.0013 | 0.0016 | 0.0019 | 0.0021 |
| 46 | 0.2591 | 0.5260 | 2777 | 0.0004 | 0.0005 | 0.0008 | 0.0007 | 0.0009 | 0.0012 | 0.0013 | 0.0014 | 0.0017 | 0.0020 |
| 47 | 0.2606 | 0.5284 | 2736 | 0.0004 | 0.0005 | 0.0007 | 0.0006 | 0.0010 | 0.0013 | 0.0013 | 0.0016 | 0.0019 | 0.0021 |
| 48 | 0.2595 | 0.5284 | 2760 | 0.0004 | 0.0005 | 0.0008 | 0.0006 | 0.0008 | 0.0010 | 0.0010 | 0.0014 | 0.0017 | 0.0018 |
| 49 | 0.2597 | 0.5276 | 2757 | 0.0004 | 0.0006 | 0.0008 | 0.0008 | 0.0010 | 0.0013 | 0.0013 | 0.0016 | 0.0019 | 0.0022 |
| 50 | 0.2602 | 0.5249 | 2758 | 0.0004 | 0.0005 | 0.0008 | 0.0006 | 0.0009 | 0.0012 | 0.0013 | 0.0014 | 0.0017 | 0.0020 |
| 51 | 0.2590 | 0.5238 | 2790 | 0.0004 | 0.0005 | 0.0009 | 0.0006 | 0.0008 | 0.0011 | 0.0013 | 0.0014 | 0.0016 | 0.0018 |
| 52 | 0.2581 | 0.5272 | 2795 | 0.0004 | 0.0005 | 0.0009 | 0.0006 | 0.0009 | 0.0013 | 0.0013 | 0.0016 | 0.0018 | 0.0019 |
| 53 | 0.2593 | 0.5256 | 2776 | 0.0003 | 0.0004 | 0.0010 | 0.0008 | 0.0009 | 0.0011 | 0.0014 | 0.0017 | 0.0019 | 0.0022 |
| 54 | 0.2593 | 0.5278 | 2766 | 0.0004 | 0.0005 | 0.0007 | 0.0006 | 0.0009 | 0.0010 | 0.0011 | 0.0012 | 0.0015 | 0.0018 |
| 55 | 0.2585 | 0.5278 | 2783 | 0.0004 | 0.0005 | 0.0008 | 0.0006 | 0.0009 | 0.0012 | 0.0012 | 0.0013 | 0.0014 | 0.0016 |
| 56 | 0.2590 | 0.5260 | 2780 | 0.0004 | 0.0006 | 0.0008 | 0.0006 | 0.0009 | 0.0011 | 0.0013 | 0.0014 | 0.0015 | 0.0016 |
| 57 | 0.2595 | 0.5267 | 2766 | 0.0004 | 0.0005 | 0.0008 | 0.0006 | 0.0010 | 0.0012 | 0.0014 | 0.0016 | 0.0018 | 0.0019 |
| 58 | 0.2585 | 0.5228 | 2807 | 0.0003 | 0.0005 | 0.0012 | 0.0008 | 0.0011 | 0.0014 | 0.0015 | 0.0017 | 0.0020 | 0.0022 |
| 59 | 0.2604 | 0.5258 | 2750 | 0.0005 | 0.0005 | 0.0008 | 0.0005 | 0.0007 | 0.0010 | 0.0012 | 0.0015 | 0.0017 | 0.0019 |
| 60 | 0.2584 | 0.5253 | 2797 | 0.0005 | 0.0006 | 0.0010 | 0.0008 | 0.0009 | 0.0012 | 0.0014 | 0.0015 | 0.0017 | 0.0019 |
| Avg. | 0.2595 | 0.5266 | 2768 | 0.0004 | 0.0005 | 0.0009 | 0.0006 | 0.0009 | 0.0012 | 0.0013 | 0.0015 | 0.0017 | 0.0019 |
| Med. | 0.2595 | 0.5268 | 2766 | 0.0004 | 0.0005 | 0.0008 | 0.0006 | 0.0009 | 0.0012 | 0.0013 | 0.0015 | 0.0017 | 0.0018 |
| st dev | 0.0009 | 0.0018 | 23 | 0.0001 | 0.0001 | 0.0001 | 0.0001 | 0.0001 | 0.0001 | 0.0001 | 0.0001 | 0.0002 | 0.0002 |
| Min. | 0.2578 | 0.5228 | 2726 | 0.0003 | 0.0004 | 0.0007 | 0.0004 | 0.0006 | 0.0010 | 0.0010 | 0.0012 | 0.0014 | 0.0015 |
| Max. | 0.2612 | 0.5293 | 2816 | 0.0005 | 0.0006 | 0.0012 | 0.0009 | 0.0011 | 0.0014 | 0.0015 | 0.0017 | 0.0020 | 0.0022 |

4 - DUT Photo

4.1 Mechanical Dimensions

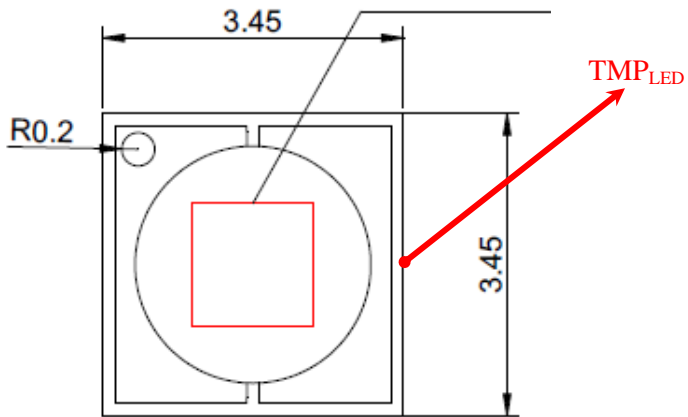

+ -

All dimensions are in millimeter

4.2 DUT Photo

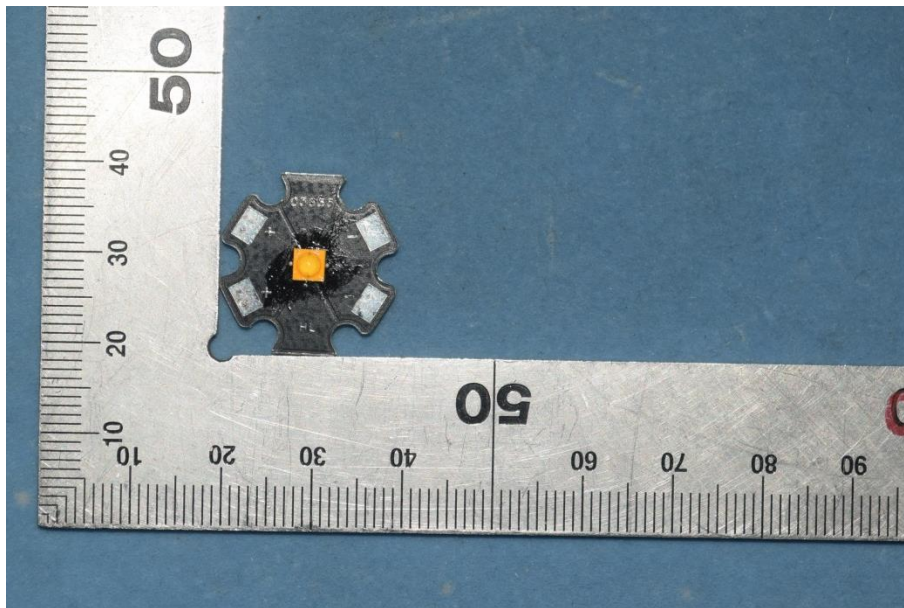



5 - Report Revision

| Report Number | Report Date | Contents |
|--------------------------|-------------|---|
| RSZ201026503-10-10000 | 2022-03-15 | Original report. |
| RSZ201026503-10-10000-M1 | 2023-11-13 | Update the family models and add L ₈₀ ,L ₉₀ reporting life in page 3 and page 7 |
| RSZ201026503-10-10000-M2 | 2024-04-25 | Updated Family products covered on page 3 to page 5 |

Directions

1. The information marked "superscript #" is provided by the applicant, the laboratory is not responsible for its authenticity and this information can affect the validity of the result in the test report.
2. Unless otherwise stated the results shown in this test report refer only to the sample(s) tested.
3. Otherwise required by the applicant or Product Regulations, Decision Rule in this report did not consider the uncertainty.
4. The extended uncertainty given in this report is obtained by combining the standard uncertainty times the coverage factor $K=2$ with the 95% confidence interval.
5. This report cannot be reproduced except in full, without prior written approval of the Company.
6. This report is valid only with a valid digital signature. The digital signature may be available only under the Adobe software above version 7.0.

*****END OF REPORT*****